

Product Components

- ① 1006 Electric Strike Body
- ② Trim Enhancer (with screws)
- ③ 12 & 24 Volt Pigtails
- ④ Keeper Shims (2, with screws)

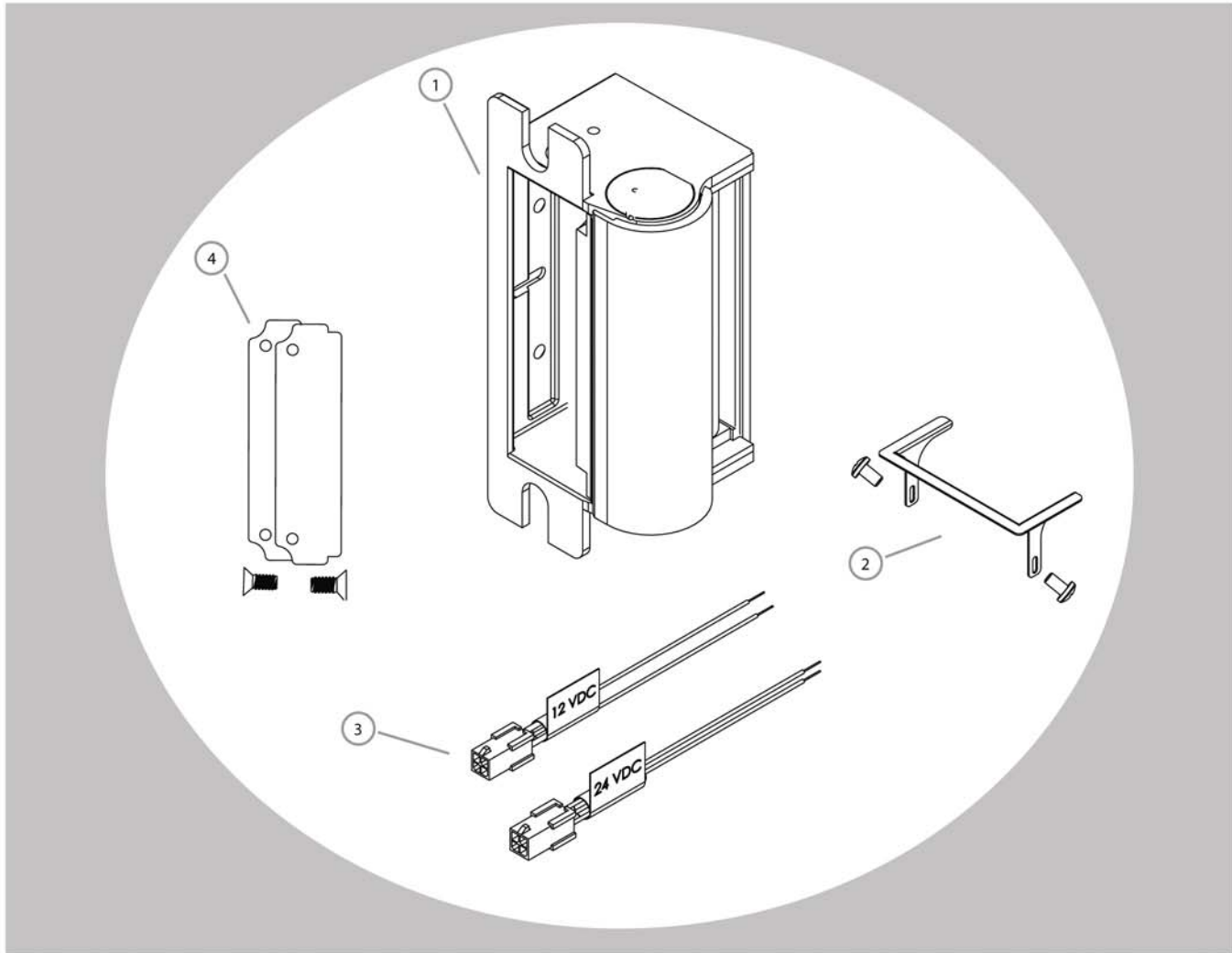

Electrical Specifications

ELECTRICAL RATINGS FOR SOLENOID		
CONTINUOUS DUTY	12VDC	24VDC
Resistance in Ohms	25	100
Amps	.48	.24
Solenoids are rated at +/- 10% indicated value.		

MINIMUM WIRE GAUGE REQUIREMENTS		
SOLENOID VOLTAGE	12VDC	24VDC
200 feet or less	18 gauge	18 gauge
200 - 300 feet	16 gauge	18 gauge
300 - 400 feet	14 gauge	16 gauge

CAUTION! Before connecting any device at the installation site, verify input voltage using a multimeter. Many power supplies and low voltage transformers operate at higher levels than listed. Any input voltage exceeding 10% of the solenoid rating may cause severe damage to the unit and will void the warranty.

Prepare Strike

1. Select the appropriate Plug In Connector that matches system power and electrically connect as illustrated in Diagram 2. For 12V DC, the pigtail marked "12 VDC" should be used. For 24V DC, the pigtail marked "24 VDC" should be used. If no connector is present, configure the wires as illustrated within Diagram 2.
2. If your strike is supplied with the LATCHBOLT MONITOR (LBM), or LATCHBOLT STRIKE MONITOR (LBSM), see Diagrams 3 & 4 for wiring instructions.
3. For available faceplate options, see page 4.

Prepare Frame

4. Prepare frame using appropriate template for your lockset and faceplate combination (see page 3).

Finish Installing

5. Attach the electric strike to the jamb using the screws provided with the faceplate option kit.

DIAGRAM 2: 12V to 24V CONVERSION

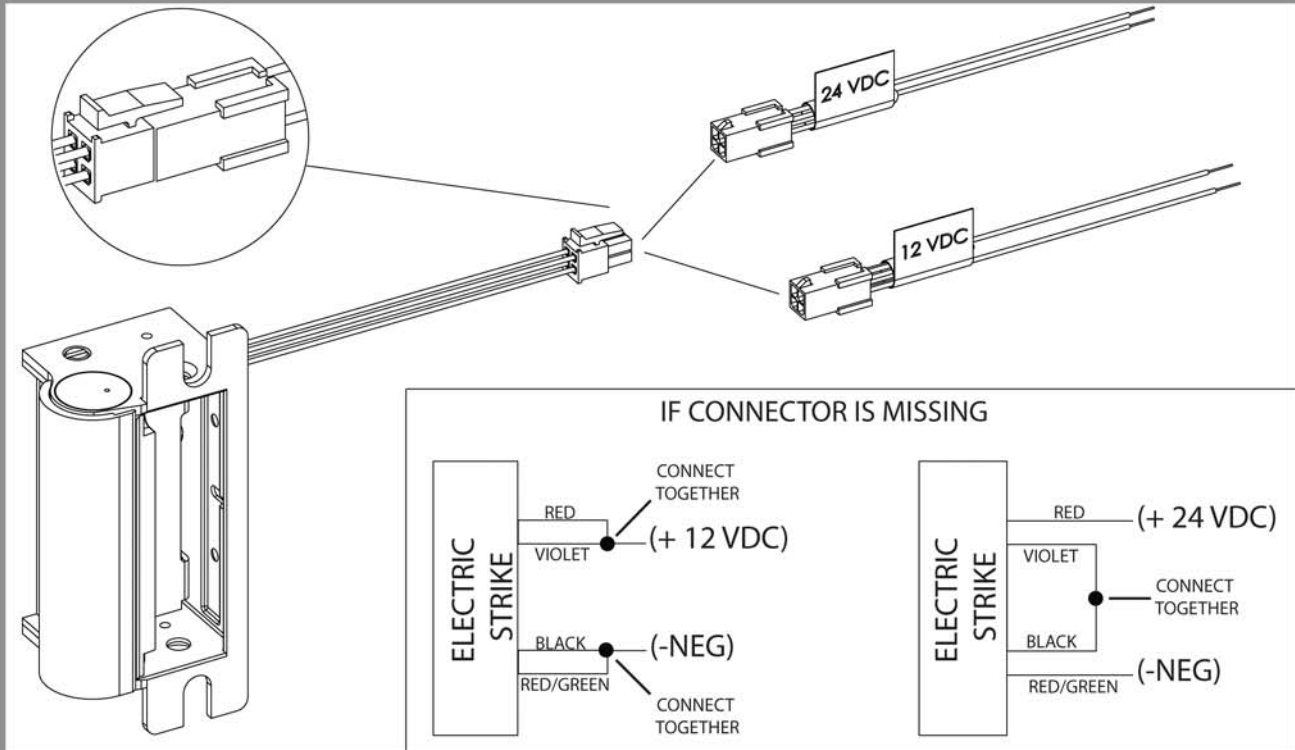

DIAGRAM 3: LATCHBOLT MONITOR

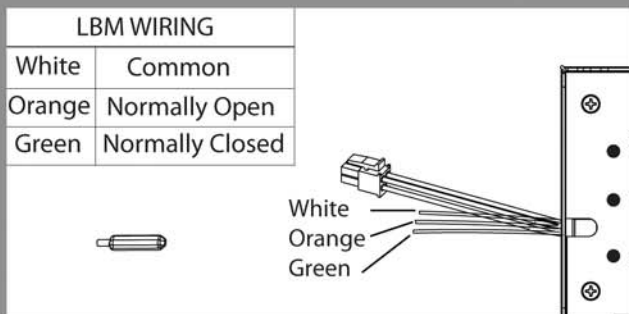
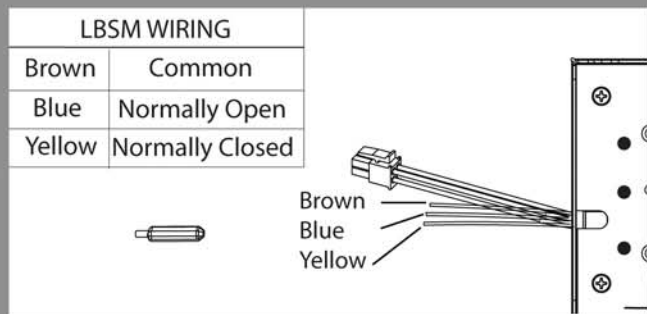
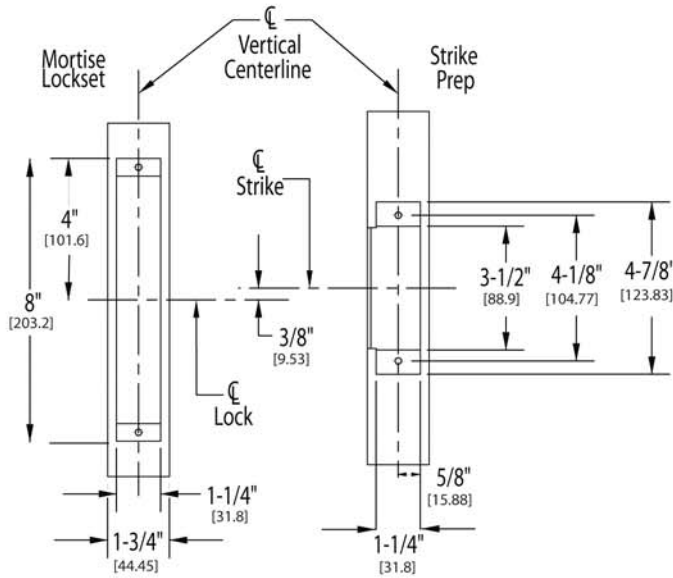

DIAGRAM 4: LATCHBOLT STRIKE MONITOR



1006 WITH MORTISE LOCKSETS

Please note the horizontal centerline of the electric strike in relation to the centerline of the mortise lockset.



1006 WITH CYLINDRICAL LOCKSETS

Please note the horizontal centerline of the electric strike in relation to the centerline of the cylindrical lockset.

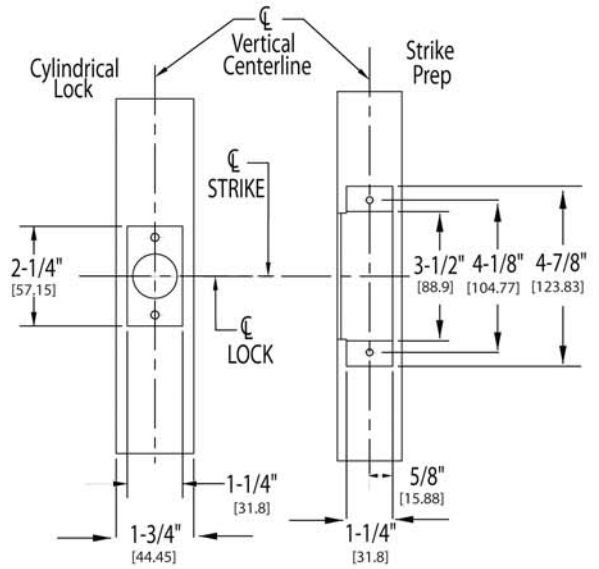

METAL JAMB INSTALLATION FOR 1006 SERIES FACEPLATES

Cutout dimensions for option faceplates: J, K, KM, N, NM, A, AM, H, HM, HT, T, Z, R and E

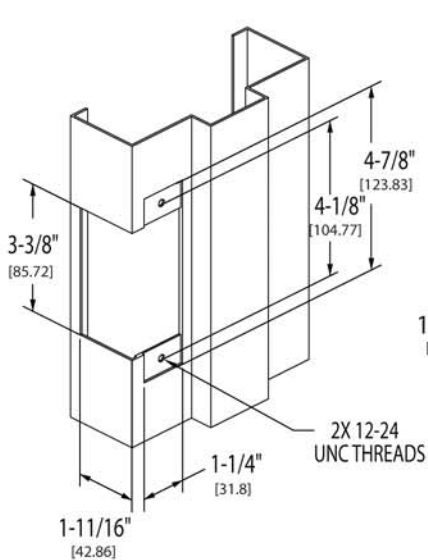

METAL JAMB INSTALLATION FOR 1006-D SERIES FACEPLATES

Cutout dimensions for option faceplates: KD, ND, AD, HD, HTD and TD

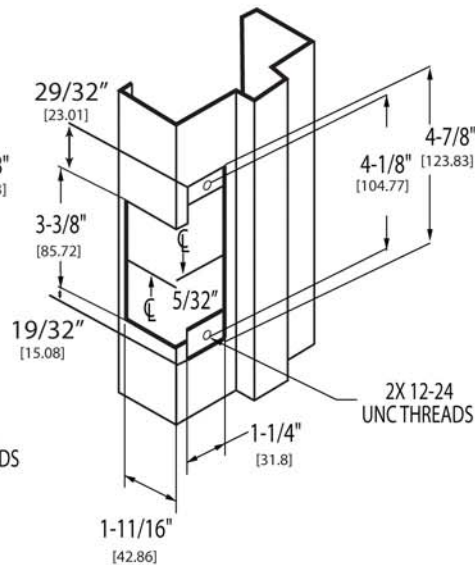

WOOD JAMB INSTALLATION FOR 1006-2 SERIES FACEPLATES

Cutout dimensions for option faceplates: J2, K2, KM2, N2, T2, H2 AND A2

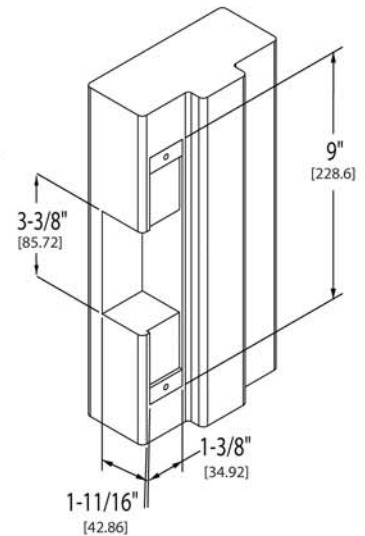

Faceplate Options

(4-7/8 x 1-1/4 SQUARE CORNER)

☒ = center line of faceplate
(2nd line = center line of faceplate opening)

Inches [mm]

AD, HD, ND & TD OPTION FACEPLATE

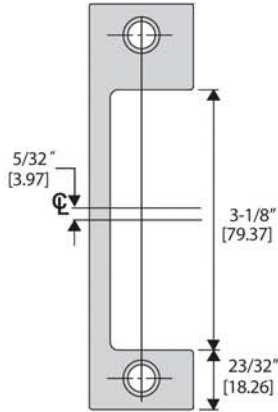

A, H, HT, N & T OPTION FACEPLATE

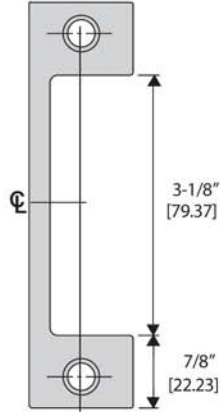

AM, HM, & NM OPTION FACEPLATE

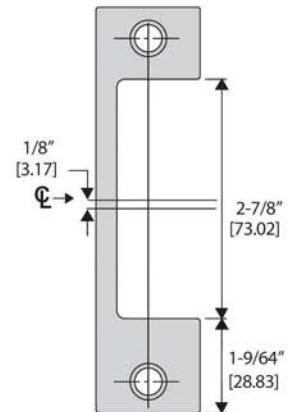

KD OPTION FACEPLATE

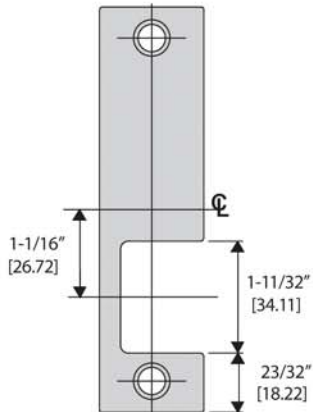

K OPTION FACEPLATE

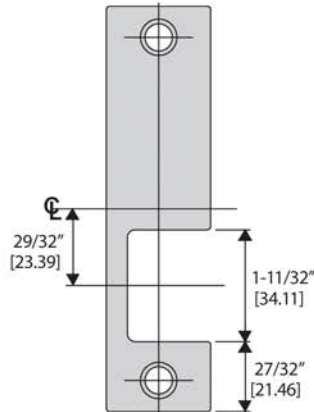

R OPTION FACEPLATE

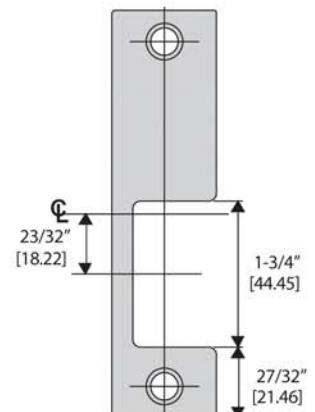

KM OPTION FACEPLATE

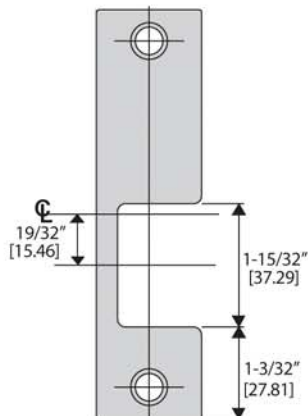

Z OPTION FACEPLATE

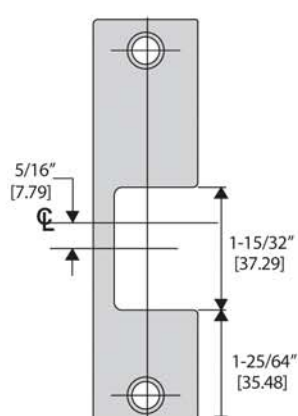

J, E OPTION FACEPLATE

